



Ra-06 Specification

Version V1
copyright ©2019

Disclaimer and copyright notice

The information in this article, including the URL address for reference, is subject to change without prior notice. The Documentation is provided "as is" without any warranty, including any warranties of merchantability, fitness for a particular purpose, or non-infringement, and any warranties mentioned in the proposal, specification or sample. This document is not responsible for any infringement of any patent rights arising out of the use of the information in this document. No license, express or implied, by estoppel or otherwise, is hereby granted.

The test data obtained in this paper are all obtained by Ai-Thinker laboratory , and the actual results may be slightly different. The Wi-Fi alliance membership mark is owned by the WiFi alliance.

All trade mark names, trademarks and registered trademarks mentioned herein are the property of their respective owners and are hereby declared.

The final interpretation right is owned by Shenzhen Ai-Thinker Technology Co., Ltd.

Note

The contents of this manual may be changed due to the version upgrade of the product or other reasons. Shenzhen Ai-Thinker Technology Co., Ltd. reserves the right to modify the contents of this manual without any notice. This manual is only used as a guide, and Shenzhen Ai-Thinker Technology Co., Ltd. makes every effort to provide accurate information in this manual, but Shenzhen Ai-Thinker Technology Co., Ltd. does not ensure that the contents of the manual are completely true. All statements and information in this manual, and the recommendations do not constitute for any warranty, express or implied.

Contents

1.Product Overview.....	5
Features.....	5
Main parameters.....	6
Charter 1.1 main parameters instruction.....	6
2. Electrical parameters.....	7
Electrical character.....	7
SPI Interface features.....	7
3.Appearance size.....	9
4.Pin definition.....	10
Table 2.2 Pin function definition.....	10
5.Schematics.....	12
6.Design Guidance.....	12
1)Application Circuit.....	12
2)Antenna Install.....	12
3) Power Supply.....	13
4) GPIO.....	13
7.Reflow Welding Curve.....	15
8.Package Information.....	16
9.Contacts.....	16

1.Product Overview

Ai-Thinker lora Series Module (Ra-06) designed and developed by Ai-Thinker Technology Co., Ltd. RA-06 module insert SX1278 RF chip and Huada ultra low power 32 bit kernel cortex M0+ MCU HC321130F8UA,8K Byte Ram,64k Byte FLASH.The module is used for ultra-long-distance spread spectrum communication, and the radio-frequency chip sx1278. Sx1278 has a high sensitivity of over-148 dbm, a 20 dbm power output, a long transmission distance and a high reliability with semtech's lya™ patent modulation technique. At the same time, with respect to the traditional modulation technology, the Lora™ modulation technology has an obvious advantage in the anti-blocking aspect, and solves the problem that the traditional design scheme can not simultaneously balance the distance, the anti-interference and the power consumption.

Its application can be automatic meter reading, home building automation, security system, remote irrigation system.

Features

- LoRa™ modem.
- With 8K Byte RAM and 64K Byte FLASH.
- Support FSK、GFSK、MSK、GMSK、LoRa™ and OOK mode.
- Frequency supports 410MHz~525MHz.
- Operating voltage is 3.3V,maximum output +20dBm.
- Low power consumption in a received state, the received current is12.15mA , stand-by current is 1.6mA.
- High sensitivity: as low as-140dBm.
- Small volume double row stamp hole patch for SMD package.
- Support second develop.
- SPI interface, using half duplex communication, with CRC、 up to 256-byte packet engine.

Main parameters**Charter 1.1 main parameters instruction**

Model	Ra-06
Package	SMD-20
Size	16*22.8*2.2(±0.2)MM
Antenna	Spring antenna
Frequency range	410MHz~525MHz
Operating Temperature	-20 °C ~ 70 °C
Storage environment	-40 °C ~ 125 °C , < 90%RH
Power supply	2.7~3.6V, typical value 3.3V, current>300mA
Support Interface	SPI
Programmable bit rate	300kbps
Certification	REACH、RoHS

2. Electrical parameters

Electrical character

Parameter	Symbol	Min	Typ	Max	Unit
Operating Temperature	TOPR	-20	25	85	°C
Supply Voltage	VDD	2.7	3.3	3.6	V

Digital port characteristics

Description		Typ		Unit	
Operating Cooperation		803~930		MHz	
IO	Name	Min	Typ	Max	Unit
IO level	VIO	2.7	3.3	3.6	V
Low input logic level	VIL	-	-	0.2	V
High input logic level	VIH	0.8	-	-	V
Low output logic level	VOL	-	-	0.1	V
High output logic level	VOH	0.9	-	-	V

SPI Interface features

Name	Description	Condition	Min	Typ	Max	Unit
Fsck	SCK frequency	-	-	-	10	MHz
tch	SCK High level time	-	50	-	-	ns

tcl	SCK Low level time	-	50	-	-	ns
trise	SCK Rise time	-	-	5	-	ns
tfall	SCK Fall time	-	-	5	-	ns
tsetup	MOSI Time setting	Change from MOSI to the rising edge of SCK	30	-	-	ns
thold	MOSI Duration	From the rising edge of SCK to the change of MOSI	20	-	-	ns
tnsetup	NSS Set up time	From the falling edge of NSS to the rising edge of SCL	30	-	-	ns
tnhold	NSS Time maintain	From the falling edge of SCL to the rising edge of NSS,normal mode	100	-	-	ns
tnhigh	Spi Access interval NSS High level time	-	20	-	-	ns
T_DATA	DATA maintenance and set up time	-	250	-	-	ns

3.Appearance size

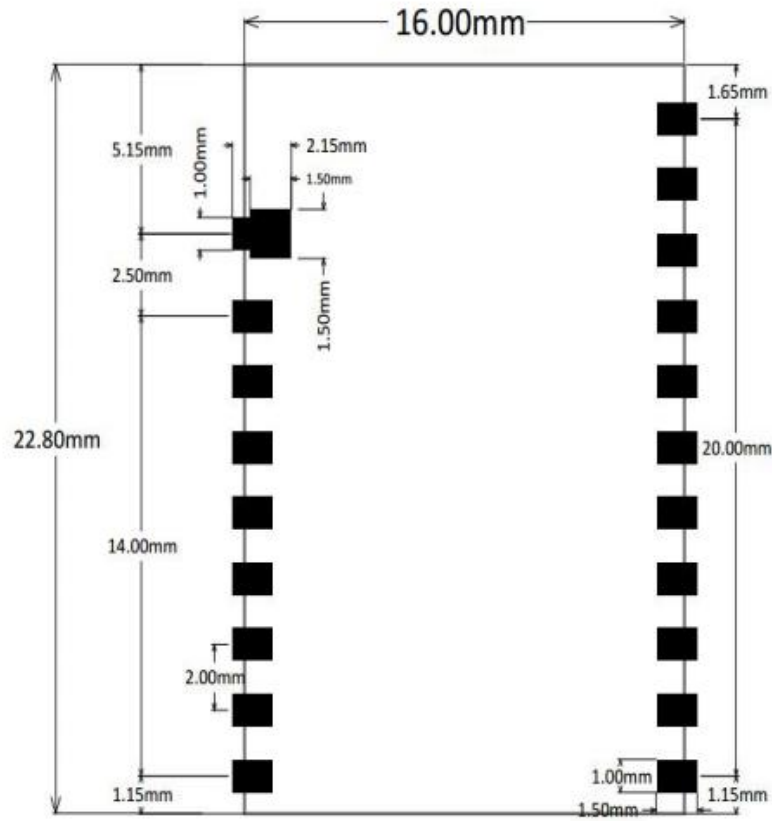
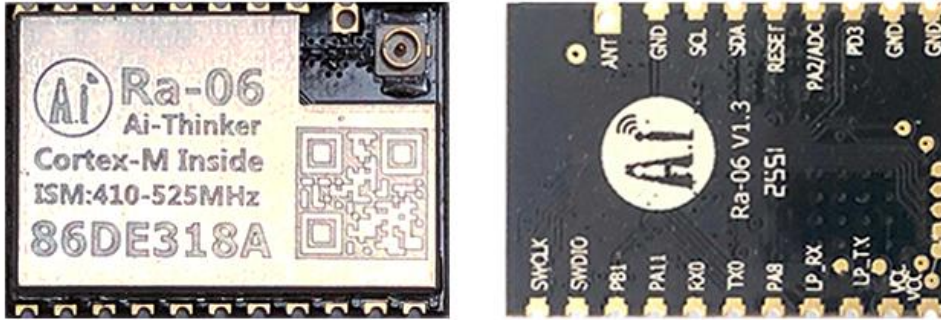

4.Pin definition

Ra-06 module with 20 interface, show as figure 2.1, table 2.2 is the interface definition.

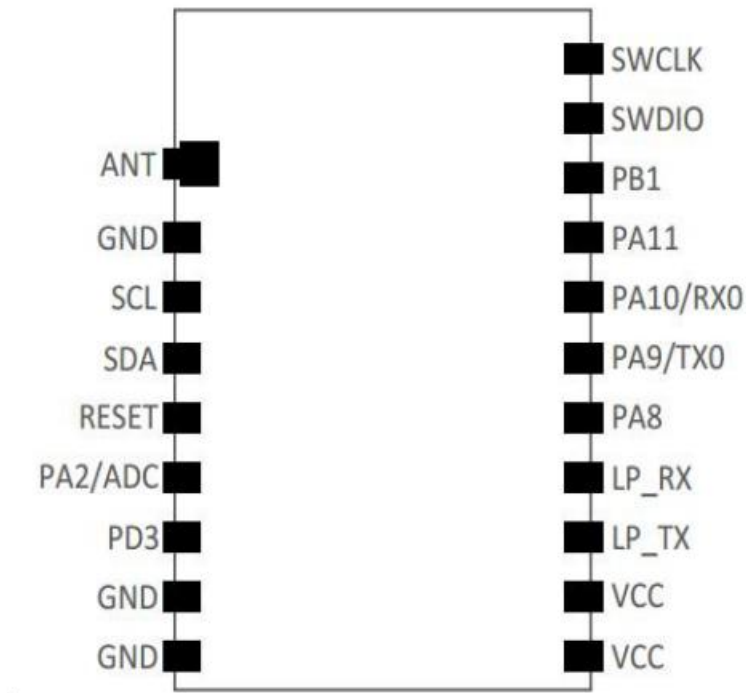

Figure 2.1 Ra-06 Pin diagram

Table 2.2 Pin function definition

No.	Name	Function instruction
1	ANT	Antenna
2	GND	Ground
3	SCL	I2C clock input
4	SDA	I2C Data interaction
5	RESET	Reset
6	PA2/ADC	ADC sampling outlet
7	PD3	Common IO Port
8	GND	Ground

9	GND	Ground
10	VCC	Power
11	VCC	Power
12	LP_TX	Common IO Port
13	LP_RX	Common IO Port
14	PAB	Common IO Port
15	PA9/TX0	UART data send port
16	PA10/RX0	UART data receive port
17	PA11	Common IO Port
18	9B1	Common IO Port
19	SWDIO	SWD program download port
20	SWCLK	

The six general IO pin of SX1278 can be available in LoRa™ mode.

Their mapping depends on the configuration of the two registers RegDioMapping1 and RegDioMapping2.

Operating Mode	DIOx Mapping	DIO5	DIO4	DIO3	DIO2	DIO1	DIO0
All	00	ModeReady	CadDetected	CadDone	Fhss Change Channel	RxRimeout	RxDone
	01	ClkOut	PIILock	Valid Header	Fhss Change Channel	Fhss Change Channel	TxDone
	10	ClkOut	PIILock	PayloadCruc Error	Fhss Change Channel	CadDetected	CadDone
	11	-	-	-	-	-	-

5.Schematics

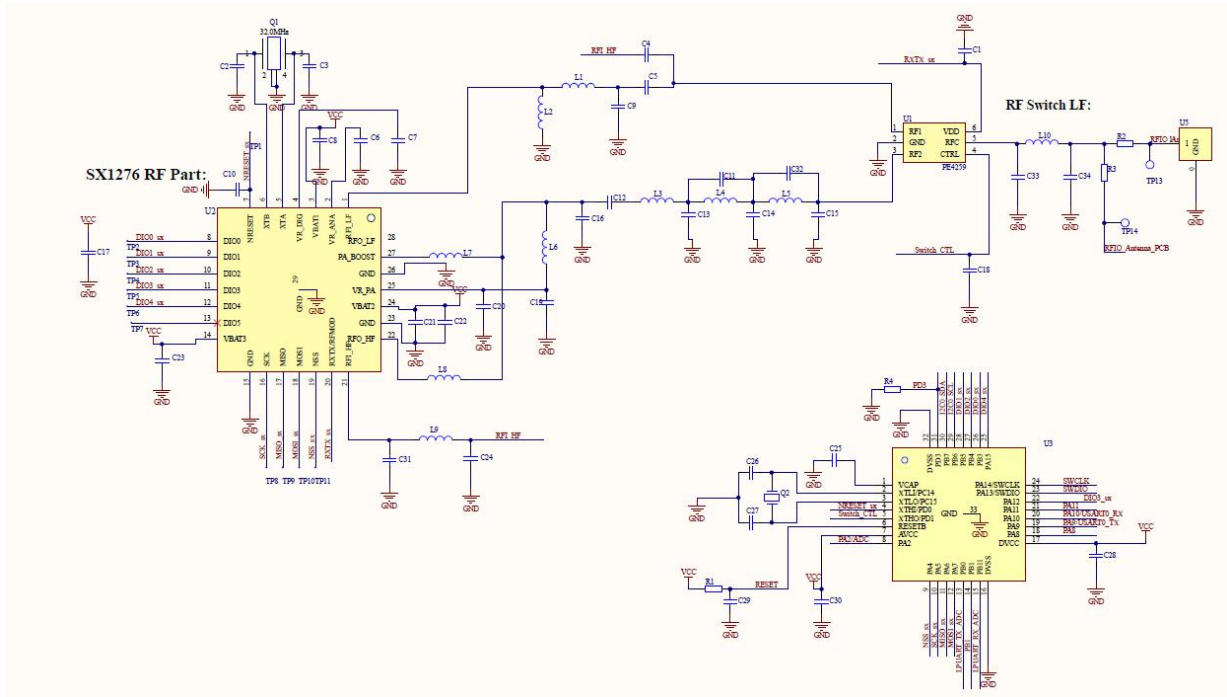

6.Design Guidance

1)Application Circuit

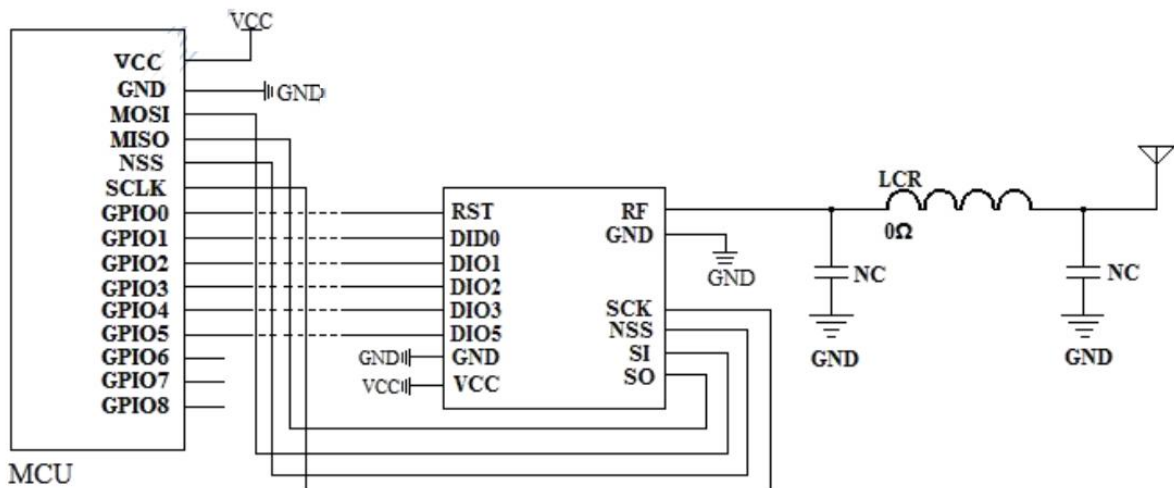

2)Antenna Install

(1)、Ra-06 is required to use external antenna, the module is compatible with the half-hole pad, the round-hole pad and IPEX.

(2)、In order to meet the performance of the on-board antenna, metal parts are prohibited from being placed around the antenna.

3) Power Supply

- (1)、Recommended voltage 3.3 V, Peak:Current over 300mA .
- (2)、It is recommended to use the LDO power supply; If DC-DC is used, the ripple is controlled within 30 mV.
- (3)、DC-DC power supply circuit is recommended to reserve the position of the dynamic response capacitor, and the output ripple can be optimized when the load change is large.
- (4)、3.3V power jack advise to add ESD components.

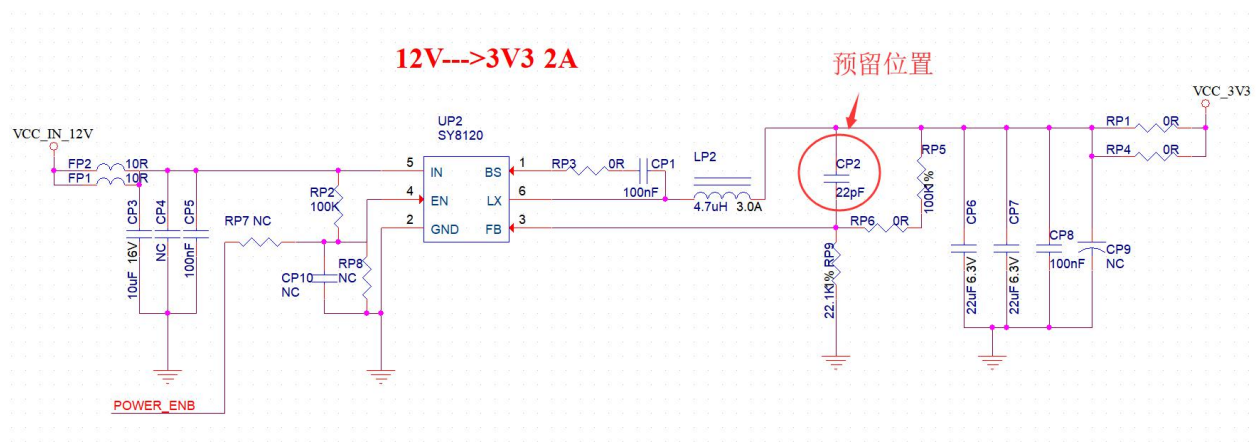

4) GPIO

- (1). There's a few GPIO port design outside the module, if require to use recommend the IO port to tadem the resistance for 10 to 100 ohmic.This can suppress overshoot , It's even more stable on both sides.It would help both EMI and ESD.
- (2) .Special IO's pull up and down, should refer to the direction of use in Specification, here will affect the startup configuration of the module.
- (3) .IO port of module is 3.3V,if master control and the IO level of module doesn't match,required to add Level swithing circuit.
- (4) .If IO port connected to out-ring interface directly, pin or other etc, recommended to reserved ESD device near the terminal of IO circuit line .

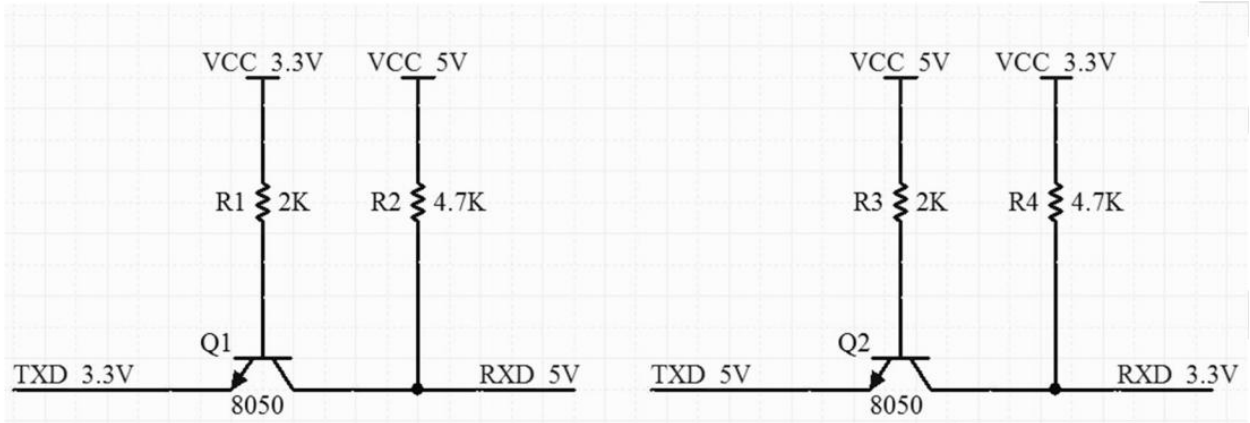

Level switching circuit

7.Reflow Welding Curve

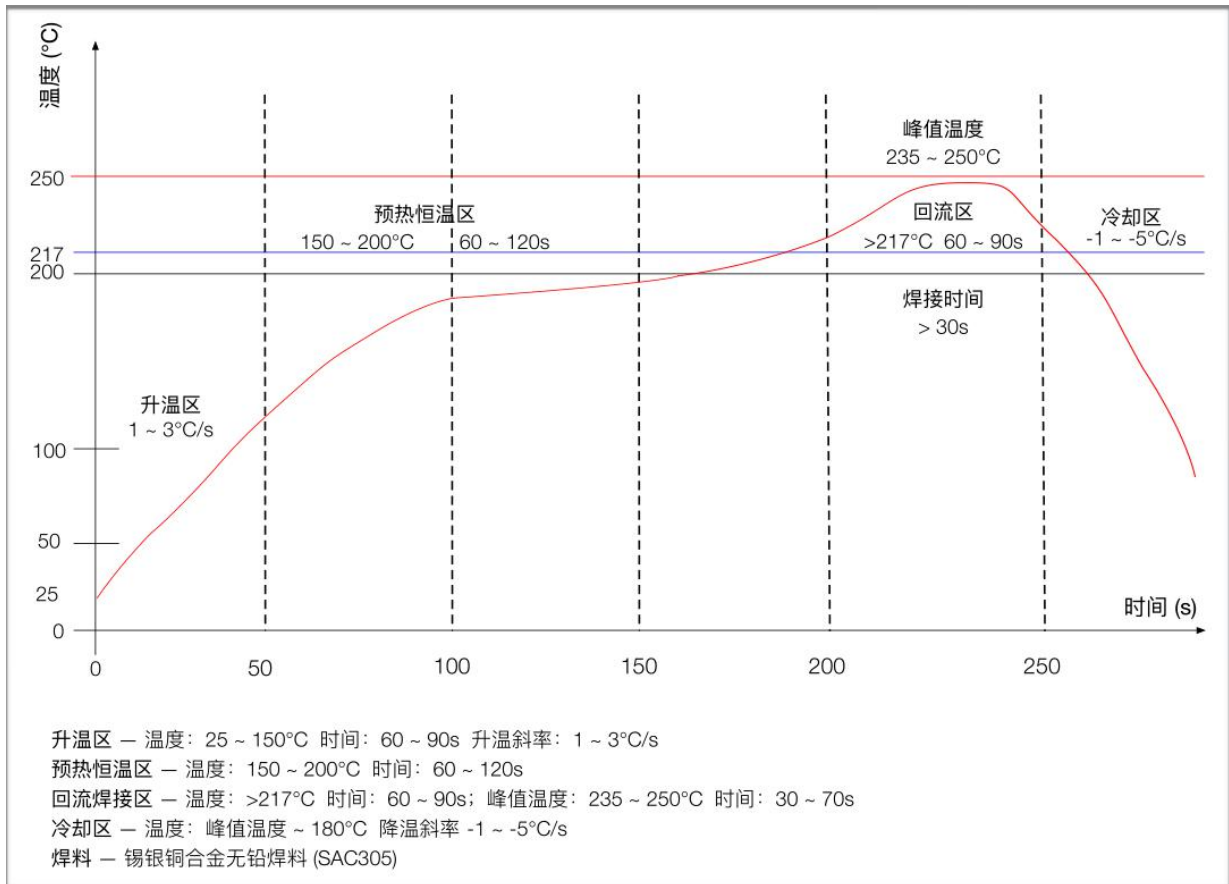

8.Package Information

As shown below,the packing of Ra-06 is a tape.



9.Contacts

Company website: <https://www.ai-thinker.com>

Developer Wiki: <http://wiki.ai-thinker.com>

Company forum: <http://bbs.ai-thinker.com>

Sampling purchasing: <https://anxinke.taobao.com>

Business cooperation: sales@aithinker.com

Technology support: support@aithinker.com

Company address: Seventh floor, Building B,xixiang street Baoan District, Shenzhen, China

Contacts: 0755-29162996

